

PRELIMINARY DATA SHEET

VK2420 4x20 ALPHANUMERIC DOT MATRIX DISPLAY MODULE WITHOUT BACKLIGHT.

FEATURES:

- Small outline low profile package.
- Low Power CMOS Circuitry.
- Wide Temperature Option.
- Suitable for interface to 8 bit or 4 bit Microprocessors.
- EL Option for Backlighting.
- On board or external contrast control.
- Single +5V Power Supply

Tabulated Data

Display format Line x Char	Font Matrix W x H (mm)	Duty	Dot Size W x H (mm)	Character size W x H (mm)	Viewing Area W x H (mm)	PCB size W x H (mm)
4 x 20	5 x 8	1/16	0.55 x 0.55	2.95 x 4.75	76.0 x 25.0	98.0 x 60.0

Dimensions in mm

VK2420

"J1"

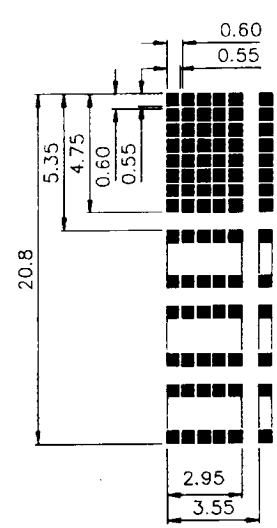
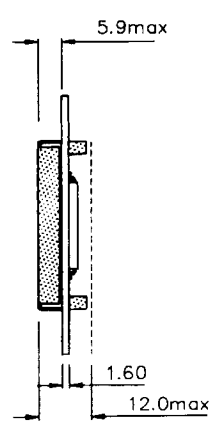
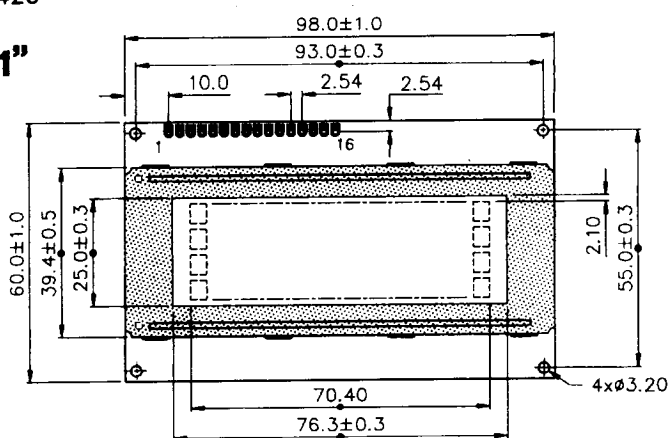

BLOCK DIAGRAM

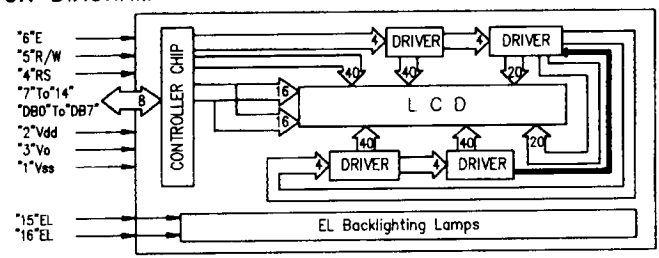

DEFINITION OF TERMINALS

PIN NO.	SYMBOL	FUNCTION
1	VSS	Ground terminal for module
2	VDD	Supply terminal for module, +5V.
3	VO	Power supply for Liquid Crystal Drive.
4	RS	Register select. RS = 0...Instruction register. RS = 1...Data register.
5	R/W	R / W = 1...Read ; R / W = 0...Write
6	E	Enable
7 ~ 14.	DB0 ~ DB7	Bi-directional Data Bus. Data transfer is performed once thru DB0 - DB7, twice thru DB4-DB7 if interfaced to 4-bit Data Length Bus. Upper 4 bits first then lower 4 bits.
15	LAMP- (L-)	LED or EL lamp power supply terminal
16	LAMP- (L+)	LED or EL lamp power supply terminal

ELECTRICAL CHARACTERISTICS

Parameter	Symbol	Condition	Min	Typ	Max	Unit
Supply voltage	V_{DD}		4.5	5	5.5	V
LCD Drive Voltage Normal temp (TN/STN)	$V_{DD}-V_O$ (V_{LCD})		4.2	4.5*	4.8	V
Wide temp (TN)			4.4	4.7*	5.0	V
Wide temp (STN)			6.4	6.8*	7.5	V
Supply Current ¹ 1x16 2x16 1x20, 2x20, 2x24 4x20, 2x40, 1x40 4x16	I_{DD}	$V_{DD} = 5V$ $V_O = 0V$ min	-	1.0	2.0	mA
			-	1.0	3.0	mA
			-	1.5	3.0	mA
			-	2.5	4.0	mA
			-	4.5	5.5	mA
Input Voltage ²	V_{IL} V_{IH}		0 2.2	- -	0.6 V_{DD}	V V
Output Voltage ³	V_{OL} V_{OH}	$I_{OL} = 1.6$ mA $I_{OH} = 0.2$ mA	- 2.4	- -	0.4 -	V V
LED Current ⁴ 1x16, 2x16 2x24, 2x20 1x20, 1x40, 2x40 4x20	I_{LED}	L+ - L- = 5V	- - -	40 60 150	60 80 250	mA mA mA

NOTES:

- Applies to DB0 - DB7, E, RS and R/W
- Applies to DB0 - DB7.
- Supply current may slightly exceed Maximum rating if Samsung controller is used without pull-up resistor for DB0-DB7
- For VK2011 - VK2014, an external limiting resistor of 6.8Ω to 10Ω is required.

POWER SUPPLY REQUIREMENTS

- Wide temperature range version.
- Standard
- Super-Twist display Version

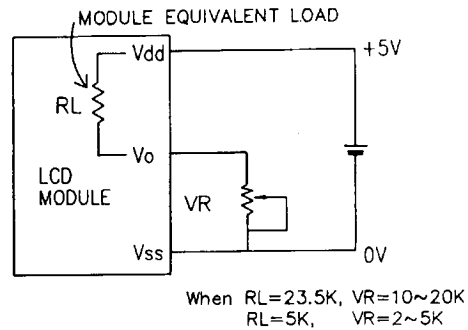

This circuit shows the typical power supply connection for all dot matrix modules.

The display voltage (V_{LCD}) is slightly different for different versions (e.g. standard, wide temperature and super twist). The use of a variable resistor as shown in the diagram is recommended for optimum V_{LCD} ($V_{DD} - V_O$). Adjust to obtain best display contrast and viewing angle

Drive Voltage (V_{LCD}) is not identical for all LCD modules. Acceptable results can be obtained by adjusting V_{LCD} . If this does not work, Vikay can modify display to meet customer needs.

OPERATING SPECIFICATIONS

	STANDARD TEMP.	WIDE TEMP.
Operating Temperature Range	0°C to +50°C	-20°C to +70°C
Storage Temperature Range	-40°C to +70°C	-40°C to +85°C

ALL LED BACKLIGHT MODELS HAVE A BUILT-IN LIMITING RESISTOR EXCEPT VK2011, VK2014

"These modules are fitted with Hitachi"compatible" controller/driver IC's which are supplied in either SMT or COB format."